



NVM Express[®] (NVMe[®]) Computational Storage

Sponsored by NVM Express[™] organization, the owner of NVMe Family of Specifications

Speakers



Kim Malone

intel®



Bill Martin

SAMSUNG



Jason Molgaard

SOLIDIGM™

Agenda

- Major architectural components
- Memory Namespaces
- Copy
- Compute Namespaces
- Program Unique Identifier (PUID)
- Memory Range Sets
- Computational programs
- Reachability
- Reachability Association example
- Example flow

Major Architectural Components

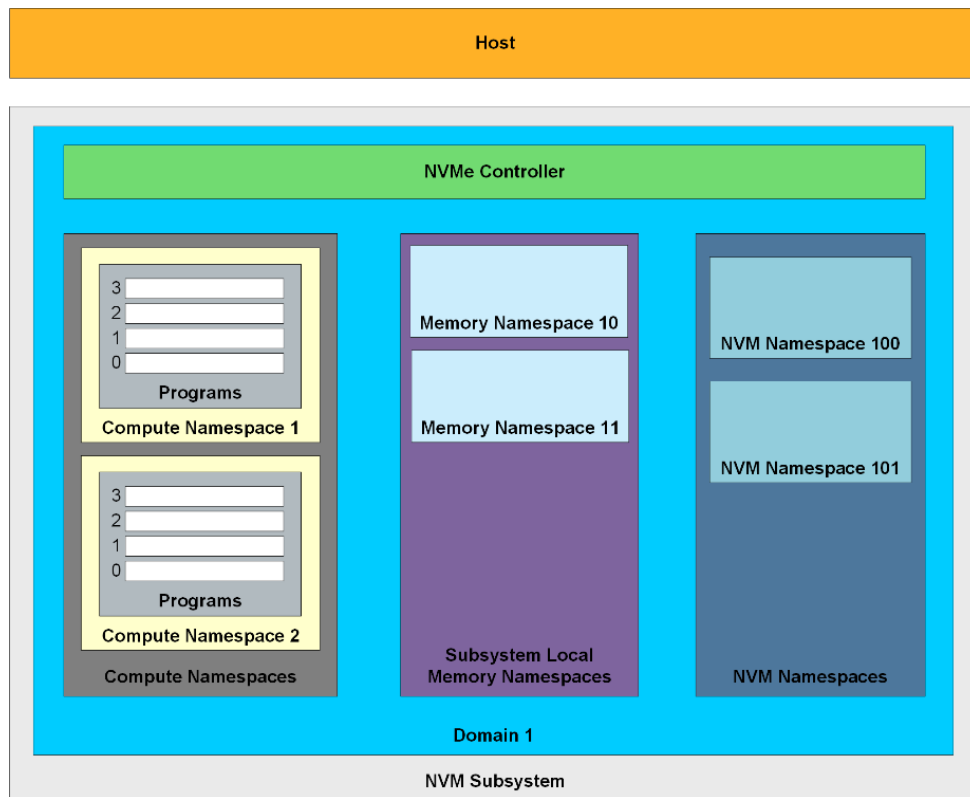

The NVM Express[®] (NVMe[®]) computational storage architecture involves several types of namespaces:

- Compute namespaces (new)
- Memory namespaces (new)
- NVM namespaces
 - NVM, Zoned and Key Value namespaces

This presentation discusses NVMe technology work in progress, which is subject to change without notice.

Memory Namespaces

A memory namespace:

- Provides host command access to memory in the NVM subsystem
- Is associated with the Subsystem Local Memory I/O command set
- Is used by the Computational Programs command set to provide access to SLM for program execution

TP4131: Subsystem Local Memory (SLM)

New Subsystem Local Memory I/O command set for memory namespaces

- New commands include:
 - Memory read and memory write
 - Commands for transferring data between host memory and a memory namespace
 - Memory copy
 - Command for copying data from NVM and memory namespaces to a memory namespace
- Host accesses are dword addressable & dword granular
- Compute Namespace accesses are byte addressable & byte granular

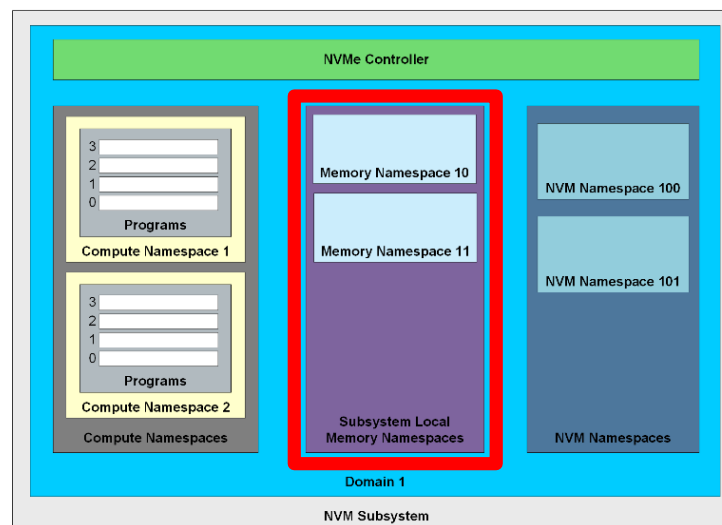

This presentation discusses NVMe® technology work in progress, which is subject to change without notice.

Copy

Memory Copy command:

- Defined in SLM command set
- Copies from NVM namespaces or from memory namespaces to a memory namespace
- Copies from NVM namespaces to memory namespace
 - Total length has to be on granularity of LBA size
 - Does conversions from blocks to bytes
- From memory namespaces to memory namespace
 - Total length has to be dword granular

NVM Copy command:

- Defined in the NVM command set
- Copies from memory namespaces or NVM namespaces to an NVM namespace
- From memory namespaces to NVM namespace
 - Does conversion from bytes to blocks
- Total length has to be on granularity of LBA size

Compute Namespaces

A compute namespace:

- Is able to execute one or more programs
- Is associated with the Computational Programs I/O command set
- Contains compute resources

TP4091: Computational Programs

New Computational Programs I/O command set for compute namespaces

- New commands include:
 - Load program
 - Activate program
 - Create/Delete Memory Range Set
 - Execute program
- Provides log pages for program discovery

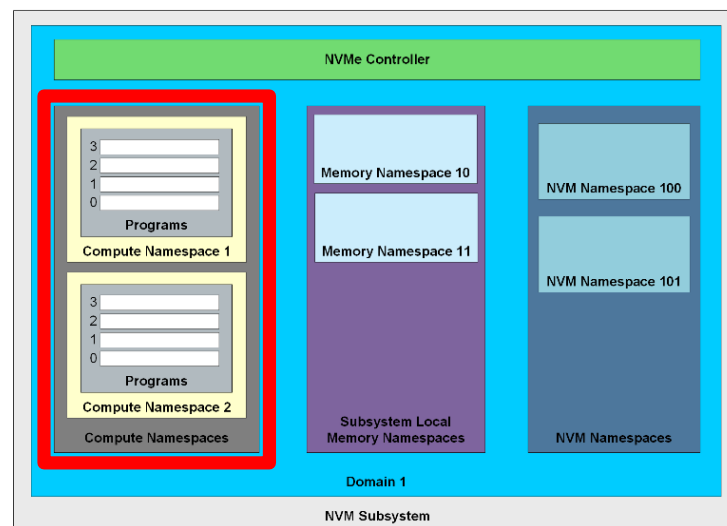

This presentation discusses NVMe® technology work in progress, which is subject to change without notice.

Program Unique Identifier (PUID)

- A Program Unique ID (PUID) is an identifier associated with specific functionality
- A PUID is composed of an IEEE assigned value and a Unique Program Identifier (UPI)
 - The UPI is unique to the organization identified by the IEEE standard value
- For programs that are NVMe[®] technology defined
 - The IEEE standard value is set to DA-E6-D7-00-0, which contains a CID assigned to an NVMe device by IEEE
 - The association of a PUID to functionality will be defined in an NVM Express[®] maintained registry
- For programs that are vendor defined
 - The IEEE standard value is set using the vendor's IEEE assigned value (OUI-24, CID-24, or OUI-36)

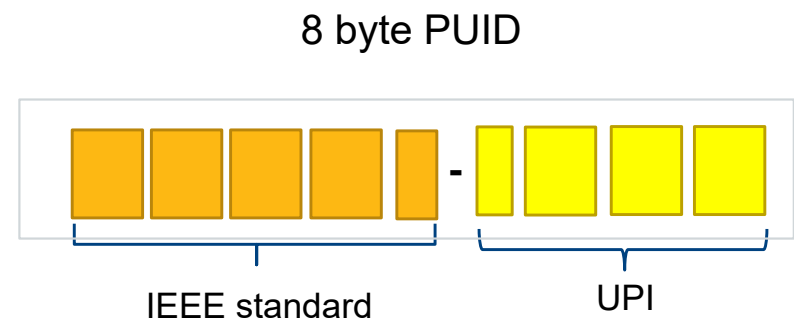

The IEEE standard value is created using one of the following:

OUI – 24 bit IEEE assigned Organizationally Unique Identifier

CID – 24 bit IEEE assigned Company ID

OUI-36 – 36 bit IEEE assigned Organizationally Unique Identifier

This presentation discusses NVMe technology work in progress, which is subject to change without notice.

Memory Range Set (MRS)

- A Memory Range Set describes one or more ranges of Subsystem Local Memory (SLM).
- A Memory Range Set is composed of Memory Ranges
 - Each range is specified by a memory Namespace ID, an offset, and a length.
 - Each range must only specify a namespace that is reachable by the compute namespace
- A Memory Range Set is created in a specific compute namespace.
- Memory Range Sets are used for the purpose of limiting program access to a specific subset of SLM.
 - Each execution of a program is restricted from accessing any SLM other than what is specified by the Memory Range Set in the Execute Program command

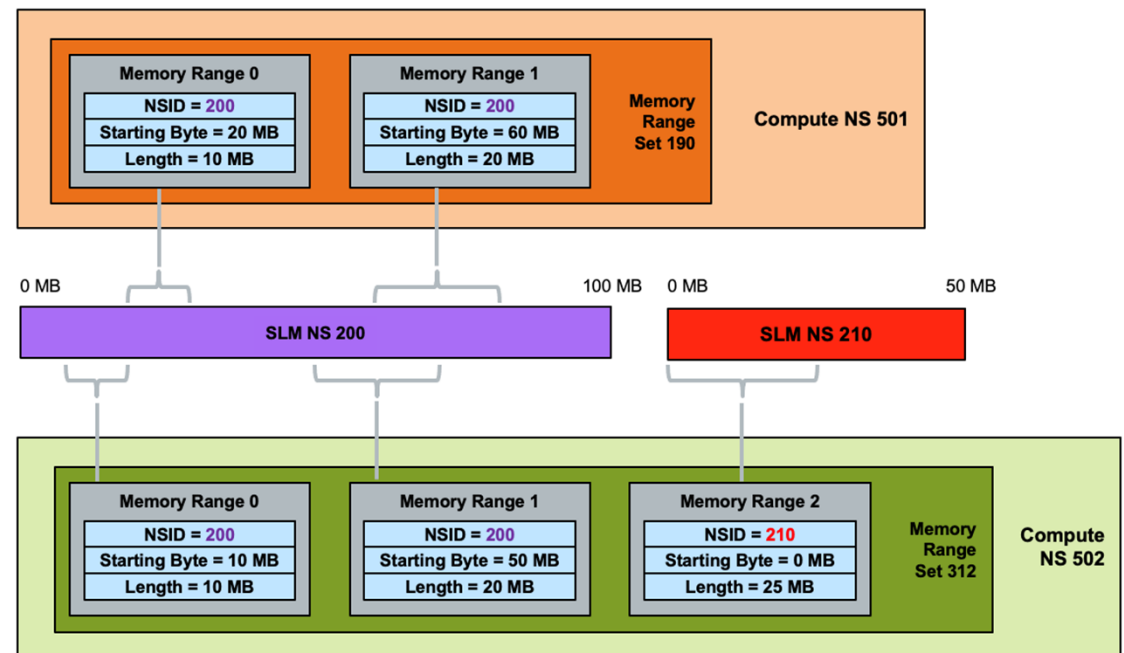

This presentation discusses NVMe® technology work in progress, which is subject to change without notice.

Computational Programs

- Conceptually similar to software functions
 - Called with parameters and run to completion
- Are addressed via a compute namespace program index
- May be identified by a globally unique program identifier
- Operate only on data in Subsystem Local Memory
- May be device-defined or downloadable
 - Device-defined programs
 - Programs provided at time of manufacture e.g., compression, encryption
 - Downloadable programs
 - Programs that are loaded to a Computational Programs namespace by the host
- A program may only be able to execute on a subset of the compute resources in an NVM subsystem
 - A program may be implemented in an ASIC
 - A program may be executed on a CPU core

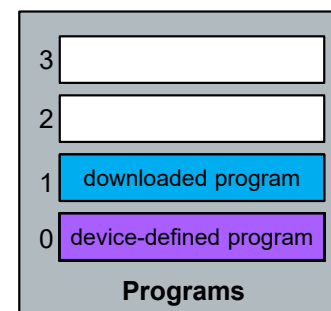

This presentation discusses NVMe® technology work in progress, which is subject to change without notice.

Reachability

Reachability is a new feature in the NVM Express® Base Specification

TP4156: Reachability

- Defines descriptors that specify what namespaces are able to be used together in a command. For example:
 - Which namespaces may be specified in a copy command
 - Which memory namespace may be specified in a command to a Compute Namespace
- Mechanism
 - Defines a Reachability Groups (RG) log page
 - Defines a Reachability Association (RA) log page
 - This log page defines characteristics, if any, of each Reachability Association

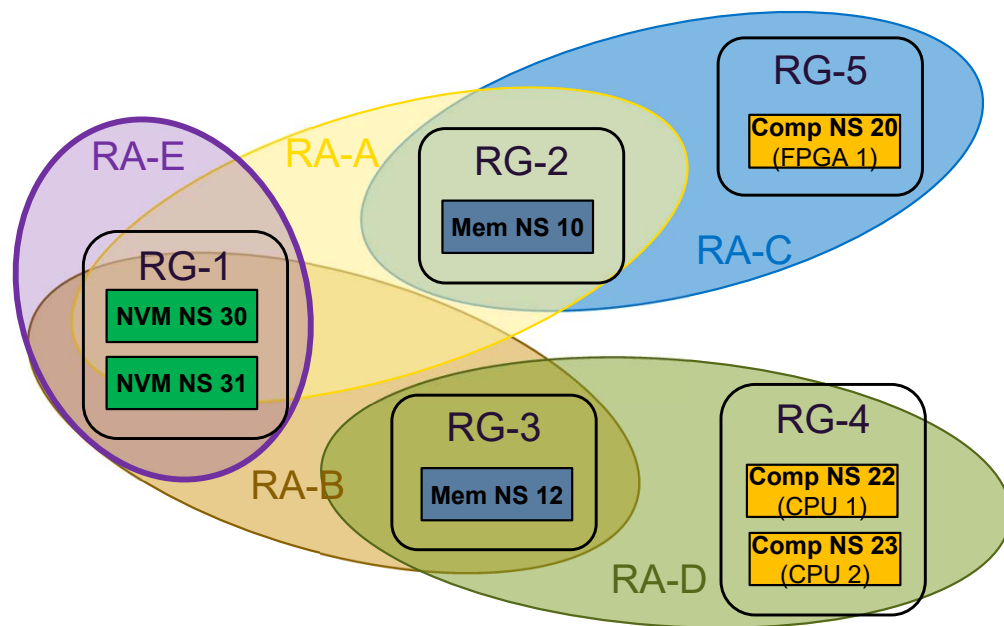

This presentation discusses NVMe® technology work in progress, which is subject to change without notice.

Reachability Associations (RA) Example

RA Meaning

- A** Copy is possible between NS 30 or NS 31 and NS 10
- B** Copy is possible between NS 30 or NS 31 and NS 12
- C** Compute NS 20 may use memory in NS 10
- D** Compute NS 22 and NS 23 may use memory in NS 12
- E** Copy is possible between NS 30 and NS 31

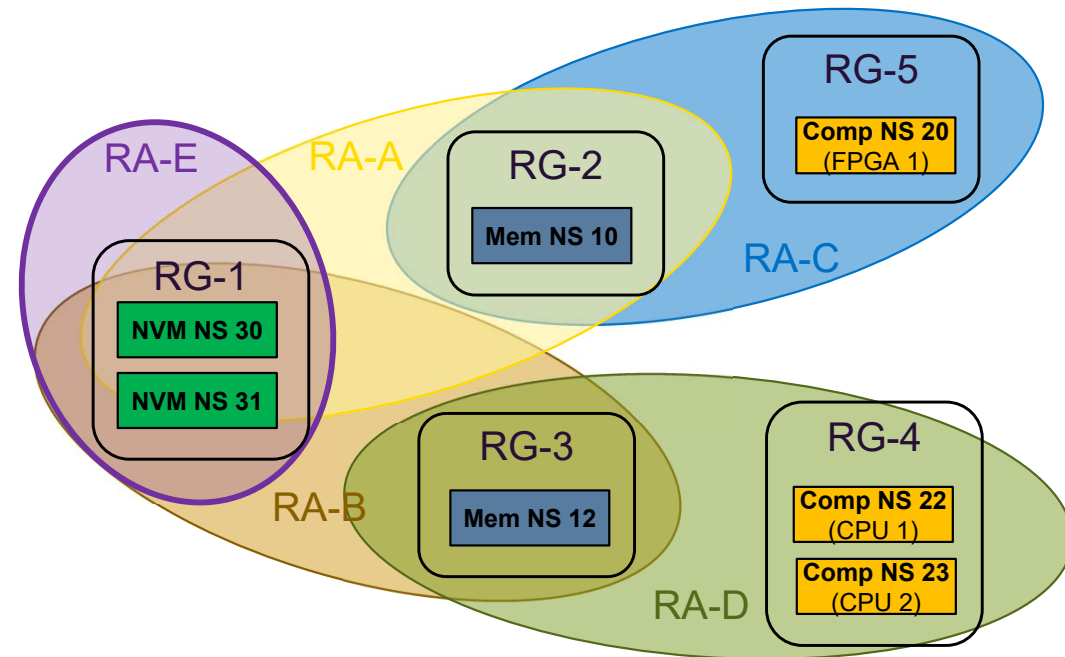

- Memory NS 10 and NS 11 CANNOT be used in a copy command to each other
- Compute NS 22 and NS 23 CANNOT communicate with each other

This presentation discusses NVMe® technology work in progress, which is subject to change without notice.



Flash Memory Summit

nvm
EXPRESS®

12

Flow: Execute Program – Filter Encrypted Data

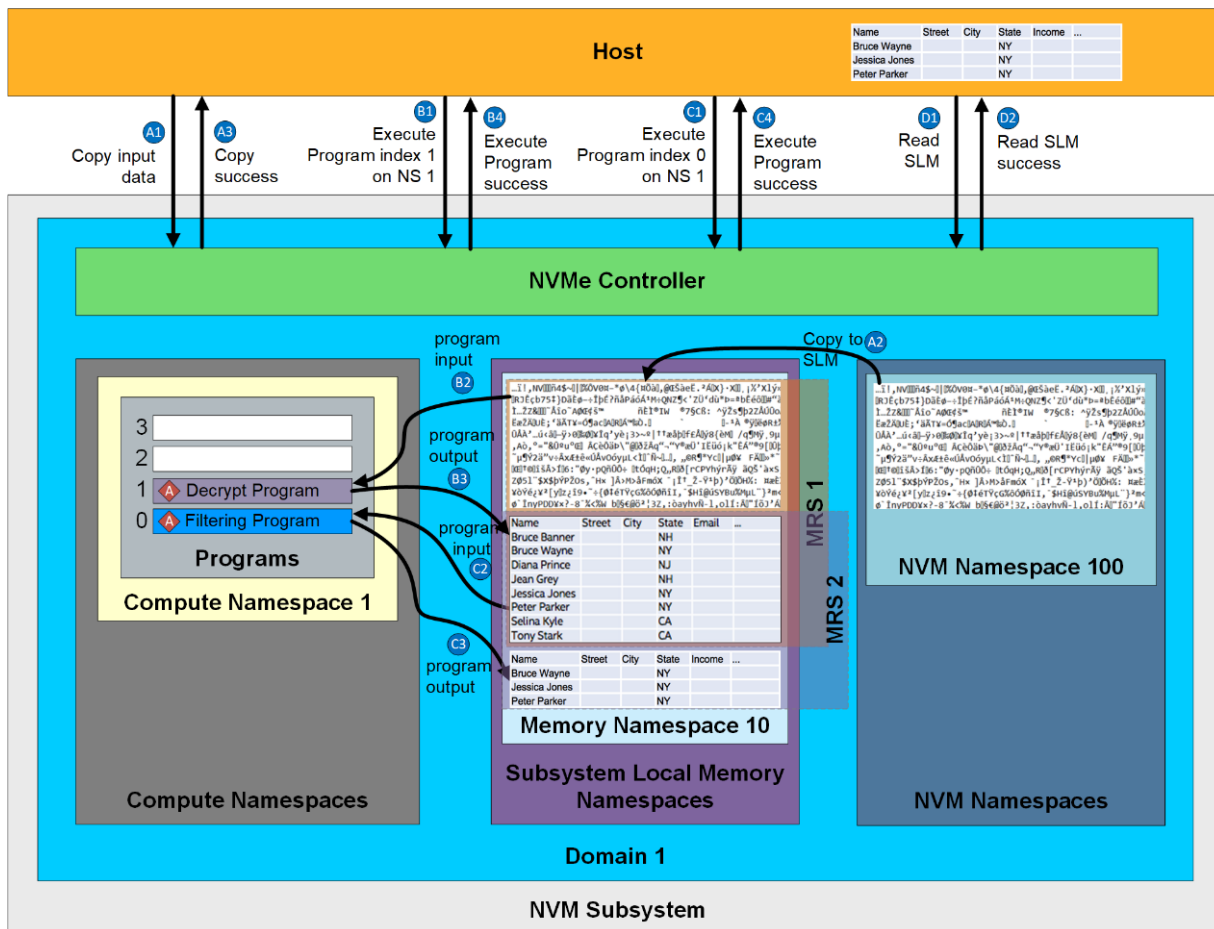

Precondition:

- Memory Range Sets MRS1 and MRS2 have been created

Flow steps

- Copy encrypted data into SLM
- Execute Program 1 on compute NS 1 using MRS1
- Execute Program 0 on compute NS 1 using MRS2
- Read filtered data from SLM to host

This presentation discusses NVMe® technology work in progress, which is subject to change without notice.

NVM Express Computational Storage Task Group

- Task Group co-chairs
 - Kim Malone (Intel)
 - Bill Martin (Samsung)
- Join the task group
 - Go to the [NVM Express workgroup portal](#)
 - Select the [CS Task Group](#)
 - Click on the “Join Group” link
- Task group meetings
 - Thursdays 9 – 10 am Pacific time

JOIN US!

Questions?



Flash Memory Summit

nvm
EXPRESS®



Architected for Performance